

# REINTAIR® & REINTAIR® WARRIOR

Plug & play purifiers to turn any indoor space into a virus-free environment





# REINTAIR® & REINTAIR® WARRIOR

Plug & play purifiers to turn any indoor space into a virus-free environment

## MAIN FUNCTION

- REINTAIR® by Casals air purifiers are plug & play sets (no installation required) to convert any interior space into an environment free of contaminating particles and thus leave a much healthier air.
- It is designed to reduce the viral load of the rooms given the constant air purifications that it carries out.

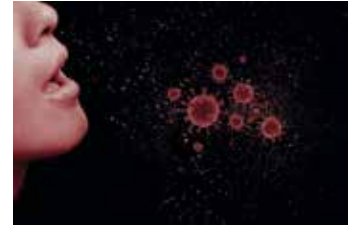

1. Reduction of dust particles, odors and contaminating microorganisms. Thus creating a healthier environment. Ideal for people with **allergies and asthma**.
2. Aside from a healthier work environment, our air purifiers **reduce the need for cleaning** by removing a large portion of the dust that is generated daily.
3. Double filtration stage with two **ABSOLUTE HEPA H14** filter packages and a Molecular filter that in a matter of hours will reduce a large number of particles in the air such as microorganisms, bacteria, viruses, molecules, etc.
4. Available version with **UV-C lamp and photocatalysis** to inert the particles captured by the filters.
5. Equipped with **high efficiency and silent fans** to guarantee low energy consumption.

## APPLICATIONS

- Designed for all kind of indoor spaces such as:
  - health sector
  - offices
  - hotels
  - homes
  - universities
  - colleges
- In short, for any public space where high-quality air purification is required since REINTAIR® purifiers are equipped with **high-efficiency HEPA H14 filters**.
- Designed to be **easily moved** in indoor spaces, which makes them the best solution for:
  - Ventilation of workstations.
  - The health sector (waiting rooms, corridors, rooms, field hospitals, common areas, clinics, pharmacies, etc.).
  - The tertiary and industrial sector (offices, hotels, universities, schools, public institutions, warehouses, living rooms in restaurants).
  - The residential sector (single-family flats and houses).





## IMPORTANT

The REINTAIR purification system ensures the reduction of viral load by retaining viruses and bacteria (including COVID-19 coronaviruses) that pass through its high efficiency HEPA 14 filters. 100% air purification cannot be guaranteed in a specific space as it depends on different factors such as: architectural distribution of its location, external air currents, minimum operating time, improper use of the unit, obstruction of air inlets, maintenance level of the unit and the state of your filters, etc.

## MANUFACTURING FEATURES

- **High efficiency** purification unit built in **soundproof** steel structure, galvanized for corrosion resistance.
- Equipped with electronic EC motor, and available two constructive sizes:

MODEL	EQUIPMENT	APPLICABLE SURFACE
REINTAIR® S EC	EC motor	Up to 300m <sup>3</sup> /h for indoor spaces up to 45m <sup>2</sup> .
REINTAIR® S WARRIOR EC	EC motor, UV-C lamp and photocatalysis.	
REINTAIR® L EC	EC motor	Up to 600m <sup>3</sup> /h for indoor spaces up to 90m <sup>2</sup> .
REINTAIR® L WARRIOR EC	EC motor, UV-C lamp and photocatalysis.	

### CHASIS:

- **Soundproof** 30mm extruded aluminum profile, nylon corners and pre lacquered steel sandwich panels, RAL 9006, class M0, with 25mm internal rockwool insulation class A1 (non combustible) and 90Kg/m<sup>3</sup> density. Panels come with quick release **fastening system** for easy assembly and disassembly whenever required, whether for cleaning, maintenance or panel repositioning.
- **Filters** are located in the perforated side panels, with **knobs and fastening system**. This ease of access optimizes maintenance and filter replacement procedures. Filter replacement and manipulation of the REINTAIR® is recommended with the appropriate PPE's.
- REINTAIR® purifiers are equipped with **4 wheels** with brakes on the base for ease of mobility throughout the indoor spaces and a **handle** to pull the equipment with only one hand.

### FAN:

- Equipped with **high efficiency single inlet - backward impeller** with **self-cleaning** system, made of polyamide, statically and dynamically balanced at the factory.

### FILTERS:

- **Dual filtering stage** at each end of the REINTAIR® comprised of 2x ISO Coarse 65% (G4) + 2x HEPA H14.
- 4 filters per purification unit.
- The ISO Coarse 65% pre-filters increase the life of the absolute filters HEPA H14.

### MOTORS:

- **Low consumption EC** (electronically commutated) Technology exterior rotor motor. IP-44 protection and class B insulation. Standard voltage 230V 50Hz/60Hz.

### CONTROL PANEL:

- All REINTAIR® air purifiers are equipped with a master control panel located on one side of the structure.
- This control panel allows for control of the following parameters:
  1. On/Off of the air Purifier.
  2. Automatic function – Autonomous.
  3. Flow adjustment, 0 being the lowest and 10 the highest.
  4. Schedule control for night mode optimization and thus favouring low energy consumption when the interior spaces are empty.
  5. Clogged filter alarm and maintenance indication.
  6. Only in REINTAIR® WARRIOR version: total management of the UV-C lamp and photocatalysis such as the daily and hourly timer, or turning the lamp and photocatalysis on and off.

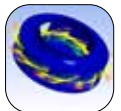



**REINTAIR® WARRIOR EC VERSIÓN**

- All REINTAIR® WARRIOR EC purifiers have the same equipment as standard REINTAIR® EC, but they also have the PHOTOCATALYSIS-UVC TOWER by Casals installed, consisting of a UV-C ultraviolet light lamp and a photocatalysis system that allows destroying the particles previously captured by the filters.
- PHOTOCATALYSIS-UVC TOWER by Casals carries out a photocatalytic oxidation process that combines UVC irradiation with a substance (catalyst) titanium dioxide (TiO<sub>2</sub>) which results in a reaction that changes harmful contaminants (bacteria, viruses and volatile organic compounds or VOC's) into H<sub>2</sub>O, CO<sub>2</sub> and detritus.
- The air purification process of using photocatalytic oxidation works by using an existing air system that pulls air through the REINTAIR® which passes through the professionally installed ultraviolet light/ titanium dioxide chamber. As the malignant contaminant-filled ambient air circulates through these chamber the microbes are "attacked" by free hydroxyl radicals and super-oxide ions (created by UV light and titanium dioxide) breaking their cellular structure apart and destroying both the intracellular mass and DNA/ RNA chromosomes. The result is harmless water molecules, carbon dioxide and detritus.

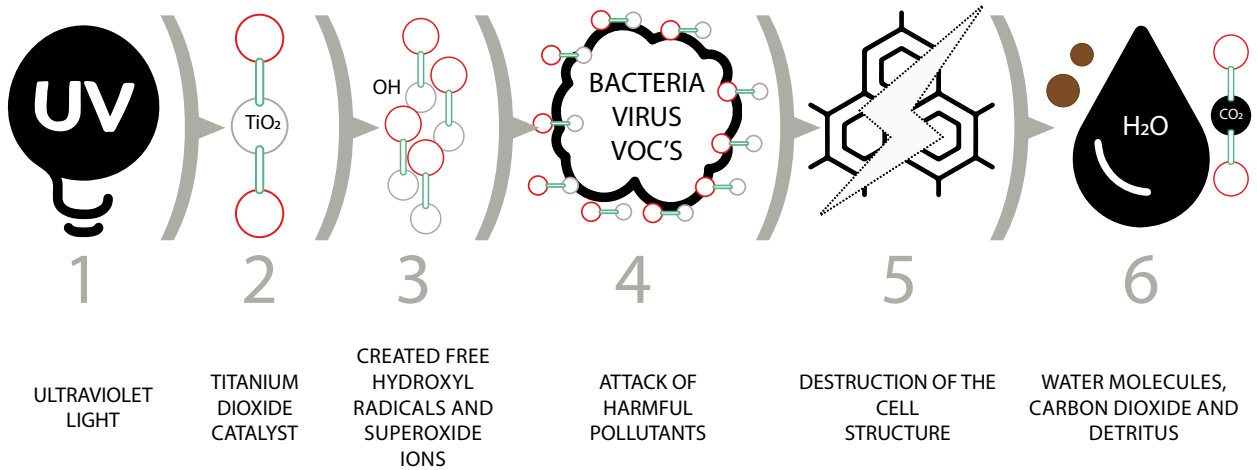

**OPERATING SCHEME**

Box containing electronic ballasts for the operation of the ultraviolet lamp



TiO<sub>2</sub> catalyst with ultraviolet light lamp inside





**EXTERNAL DIMENSIONS**

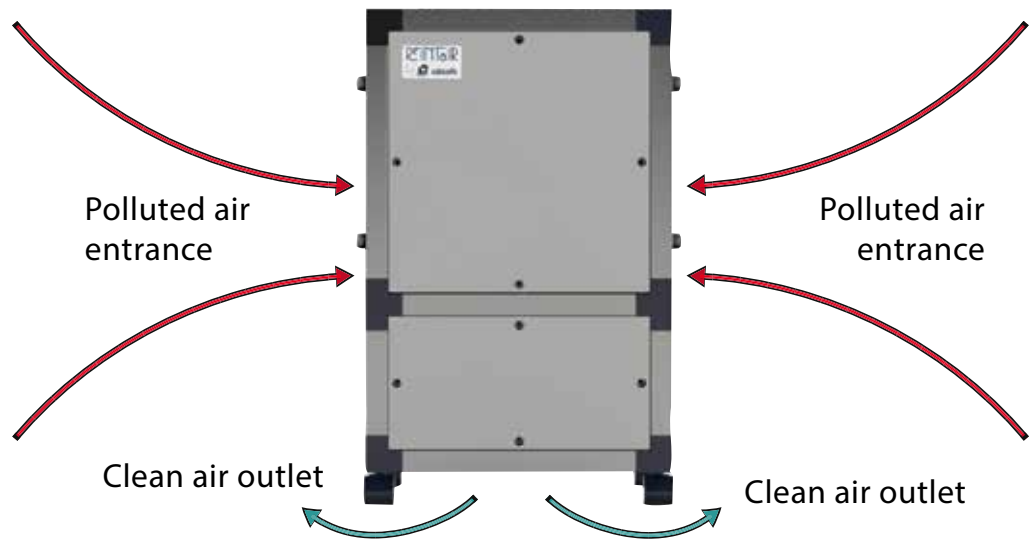
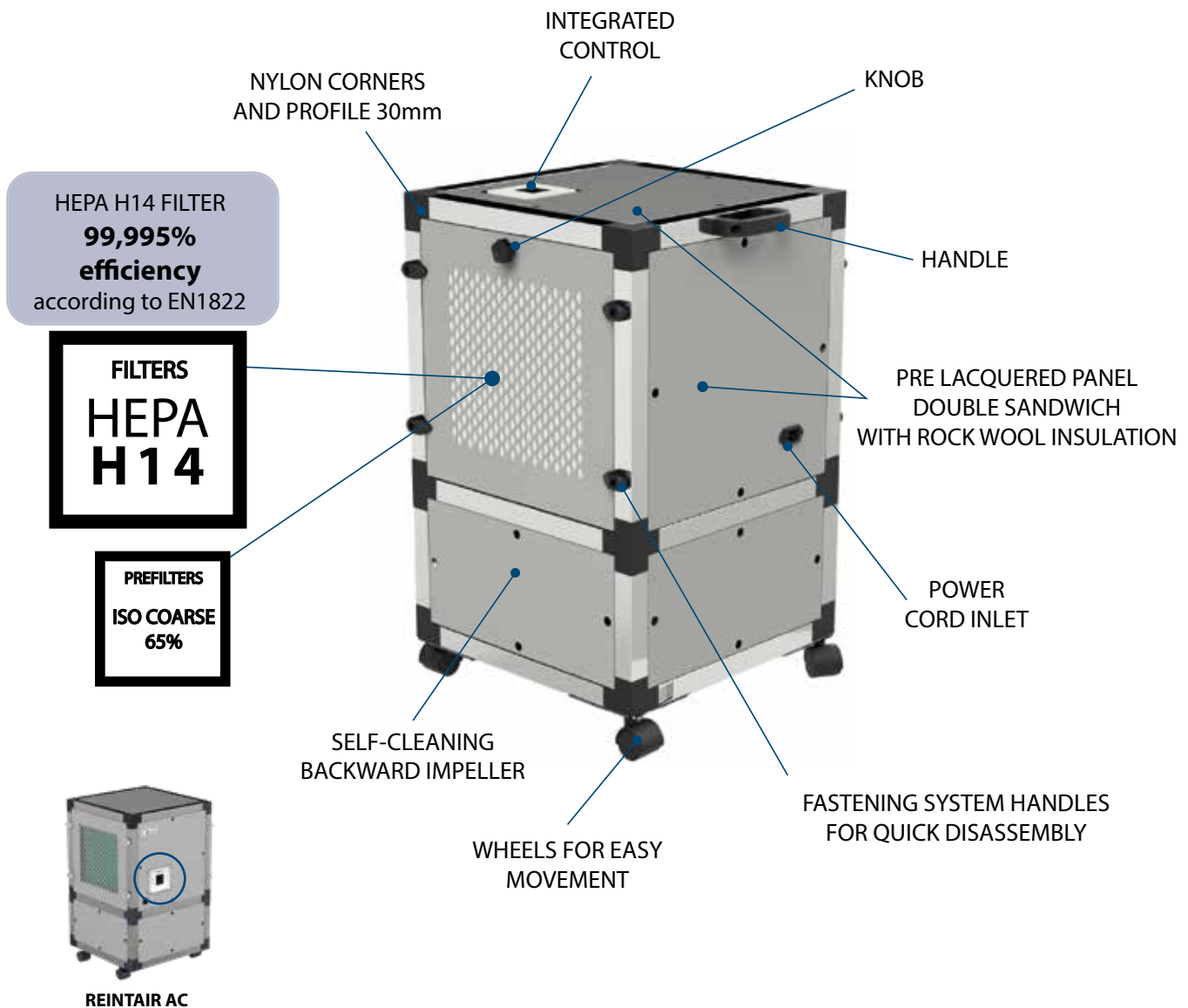



	REINTAIR® S	REINTAIR® L
Height with wheels (mm)	670	975
Width (mm)	412	412
Length (mm)	412	412
Total Weight (Kg)	30	50

REINTAIR S 300

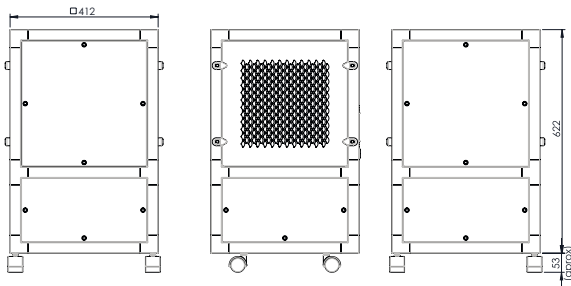

REINTAIR L 600

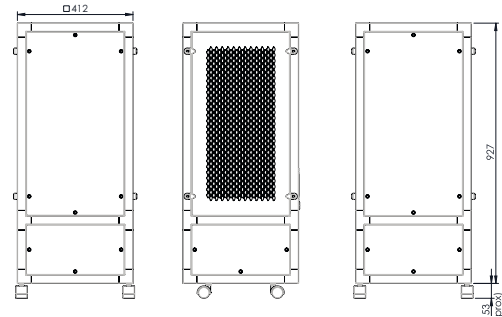

#### TECHNICAL DATA OF REINTAIR®

	REINTAIR® S EC	REINTAIR® L EC
	REINTAIR® S WARRIOR EC	REINTAIR® L WARRIOR EC
Phase	Single phase	Single phase
Rated voltage (V)	230	230
Rated voltage range (V)	220-240	220-240
Frequency (Hz)	50/60	50/60
Max. R.P.M	3980	3600
Rated I (A) 230V	0,40	0,70
Rated Power (W)	34	78
Rated airflow (m³/h)	300	600
Sound dB(A) (at 6m)	41	44
Surfaces up to (m²)	45	90
Min. ambient temperature (°C)	-25	-25
Max. ambient temperature (°C)	50	50

Note: The REINTAIR purifiers are 100% speed adjustables.

#### TECHNICAL DATA OF FILTERS

	EFFICIENCY	DIMENSIONS WxHxD (mm)	MEDIUM AREA (m²)	AIRFLOW/ PRESSURE DROP at 0,45 m/s (m³/h / Pa)*	Weight (Kg)
HEPA FILTER REINTAIR S	H14	305 x 305 x 66	2	151/175	1,9
HEPA FILTER REINTAIR L	H14	305 x 610 x 66	4,1	301/175	3,2
ISO COARSE 65% (G4) FILTER REINTAIR S	ISO COARSE 65%	287 x 287 x 24	0,2	700/70	0,2
ISO COARSE 65% (G4) FILTER REINTAIR L	ISO COARSE 65%	287 x 592 x 24	0,3	1500/70	0,2





## VORTICE GROUP COMPANIES

### VORTICE S.P.A

Strada Cerca, 2  
Frazione di Zoate  
20067 Tribiano  
(Milan) Italy  
Tel. (+39) 02 906991  
Fax (+39) 02 90699625  
vortice.com

### VORTICE LIMITED

Beeches House-Eastern  
Avenue Burton upon Trent  
DE13 0BB United Kingdom  
Tel. (+44) 1283 492949  
Fax (+44) 1283 544121  
vortice.ltd.uk

### VORTICE INDUSTRIAL S.R.L.

Via B. Brugnoli 3,  
37063 Isola della Scala  
(Verona) Italy  
Tel. (+39) 045 6631042  
Fax (+39) 045 6631039  
vorticeindustrial.com

### CASALS VENTILACIÓN AIR INDUSTRIAL S.L.

Ctra. Camprodon, s/n 17860  
Sant Joan de les  
Abadesses  
(Girona) Spain  
Tel. (+34) 972720150  
casals.com

### VORTICE LATAM S.A.

Bodega #6  
Zona Franca Este Alajuela,  
Alajuela 20101  
Costa Rica  
Tel. (+506) 2201 6934  
vortice-latam.com

### VORTICE VENTILATION SYSTEM

(Changzhou) Co.LTD  
No. 388 West Huanghe Road  
Building 19, Changzhou  
Post Code: 213000 China  
Tel. (+86) 0519 88990150  
Fax (+86) 0519 88990151  
vortice-china.com

The descriptions and illustrations in this catalogue are intended to be indicative and not binding. Without prejudice to the essential characteristics of the products described and illustrated here, CASALS reserves the right to make, at any time and without notice, changes to parts, aesthetic details or supply of accessories to its products that are deemed to be appropriate for improvement or for any construction or commercial requirement.

This printout completely cancels and replaces all the previous ones